

# LF™ 90C Core Drill

## Technical Data Sheet



May 2009

Page 1 of 6

### PRODUCT OVERVIEW

Working from the proven LF™ 90 long stroke platform, the LF™ 90C hydraulic diamond core drill comes equipped with a Cummins Tier 3 engine to meet today's stringent emission requirements. We have standardized on the hydraulic system, as well as controls and other components from the LF™ 90D drill.

#### FEATURES:

- Cummins QSB 6.7 L Tier 3 engine provides you with the power you need.
- Patented Nitro-Chuck® – offers you performance and reliability (1 year warranty).
- Independent dual mast raising cylinders.
- 11 ft feed stroke and 16,000 lb mainline hoist improves productivity and increases depth capacity.
- Upgraded control panel for improved ergonomics.

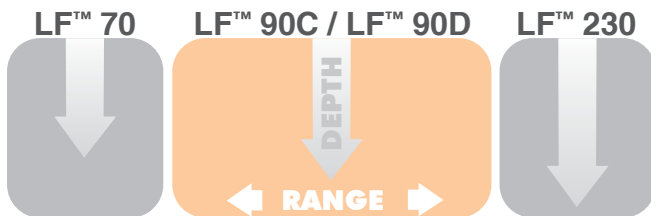
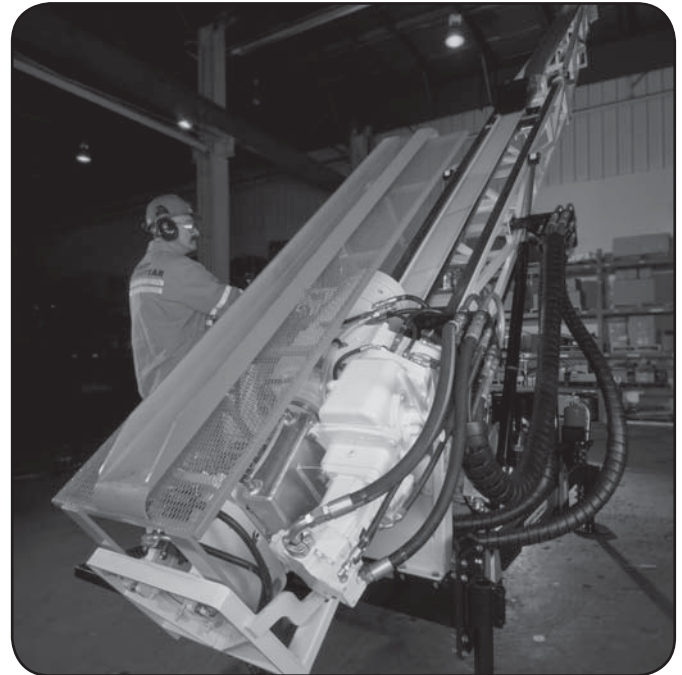

### DRILLING DEPTH GUIDELINES

The figures in these tables have been calculated, based on field experiences, and may be reasonably expected. Ratings are based on a vertical, straight, clean down hole using a

7 258 kg (16,000 lb) hoist (single line pull). Actual drilling capacity will depend on in-hole tools, conditions, drilling techniques and equipment used.

DRILL ROD / CORE BARREL	DRY HOLE		FLUID FILLED	
	Hole Depth (meters)	Hole Depth (feet)	Hole Depth (meters)	Hole Depth (feet)
BRQ / BQ	1 210	3,968	1 385	4,543
BRQTK / BQTK	1 523	4,995	1 744	5,722
NRQ / NQ / NQ2	930	3,053	1 064	3,492
NRQ V-WALL™	1 052	3,451	1 193	3,915
HRQ / HQ	631	2,071	722	2,370
HRQ V-WALL™	795	2,607	898	2,947
PHD / PQ	417	1,368	476	1,562
PHD V-WALL™	568	1,865	637	2,089

\* Always verify manufacturers rod depth ratings prior to use.

# LF™ 90C Core Drill

## Technical Data Sheet



May 2009

Page 2 of 6

### TECHNICAL SPECIFICATIONS

	METRIC SYSTEM	U.S. CUSTOMARY SYSTEM	
<b>PRIME MOVER</b>			
Standard Unit	Cummins QSB 6.7 L, liquid cooled, turbo charged, after cooled, diesel engine		
Displacement	6.7 L	409 in <sup>3</sup>	
Power (maximum) at 2,200 RPM	153 kW	220 hp	
Emissions Certification	Stage III	Tier 3	
<b>TORQUE AND RPM RATINGS</b>			
(Hydraulic motor at maximum/minimum displacement, prime mover at 2,200 RPM)			
	Speed (no load)	Torque (stall)	
	RPM	Nm	lbft
1st Gear	122 - 199	5 322 - 3 254	3,925 - 2,400
2nd Gear	246 - 400	2 648 - 1 620	1,953 - 1,195
3rd Gear	439 - 714	1 486 - 908	1,096 - 670
4th Gear	769 - 1,250	849 - 519	626 - 383
<b>NOTE:</b> Head output speed and torque are infinitely variable in each gear range as indicated.			
Actual rotation speed is affected by engine RPM and hydraulic motor displacement setting.			
<b>HYDRAULIC SYSTEM</b>			
Primary Pump	Axial piston, variable displacement load sensing, pressure compensated with low pressure standby.		
Max Flow	165 L/m	43.5 gpm	
Maximum Pressure (factory setting)	31 MPa	4,500 psi	
Secondary Pump	Axial piston, variable displacement load sensing, pressure compensated with low pressure standby.		
Max Flow	64 L/m	17 gpm	
Maximum Pressure (factory setting)	21 MPa	3,000 psi	
Auxiliary Pump	Axial piston, variable displacement load sensing, pressure compensated with low pressure standby.		
Max Flow	42 L/m	11 gpm	
Maximum Pressure (factory setting)	14 MPa	2,000 psi	
Hydraulic Tank Capacity	231 L	61 Gal	
<b>DRILL HEAD</b>			
Standard PQ - Hollow Spindle			
Rotation Motor	Rexroth hydraulic motor - variable/reversible		
Mechanical Transmission	Funk 4 speed		
Ratios	1st	6.27:1	
	2nd	3.12:1	
	3rd	1.75:1	
	4th	1.00:1	

# LF™ 90C Core Drill

## Technical Data Sheet



May 2009

Page 3 of 6

### TECHNICAL SPECIFICATIONS

	METRIC SYSTEM	U.S. CUSTOMARY SYSTEM	
<b>DRILL HEAD (cont'd)</b>			
<b>Final Drive</b>	Straight cut gears		
Ratio	2:1		
<b>Head Opener</b>	Pivot style — manual operation		
<b>Hydraulic PQ Chuck</b>	Patented Nitro-Chuck®		
	Hydraulically opened, nitrogen gas spring closed.		
	Axial holding capacity of 222 400 N (50,000 lbf)		
<b>Drill Head Lubrication</b>	Force fed bearings, oil bath for gears		
<b>Drill Head Lubricating Oil Filtration</b>	25 micron high pressure oil filter		
<b>DRILL MAST AND FEED SYSTEM</b>			
<b>Feed Stroke</b>	3.35 m	11 ft	
<b>Feed Pull</b>	111 797 N	25,133 lbf	
<b>Feed Thrust</b>	58 957 N	13,254 lbf	
<b>Rod Pull</b>	6 m	20 ft	
<b>Drilling Angle</b>	45° off horizontal to 90° vertical down		
<b>Mast Dump (Crowd)</b>	N/A	N/A	
<b>DRAW WORKS</b>			
<b>Main Line Hoist</b>	Single speed motor		
Hook Load (single part line)			
	Bare Drum	7258 kg	16,000 lb
Hoisting Speed (single part line)			
	Bare Drum	53 m/min	173 ft/min
Main Hoist Cable	15 mm	0.59 in	
Minimum Breaking Strength	23 042 kg	50,800 lb	
<b>NOTE:</b> Do not use multiple part lines with the main line hoist, use single part line ONLY.			
<b>Foot Clamp Capacity</b>	HWT		
<b>Wireline Hoist</b>			
Level Wind	N/A		
Line Pull			
	Bare Drum	993 kg	2,190 lb
	Full Drum	228 kg	502 lb
Line Speed			
	Bare Drum	145 m/min	475 ft/min
	Full Drum	433 m/min	1,422 ft/min
Drum Capacity (4.8 mm/3/16" swaged)	1 890 m	6,200 ft	
Minimum Breaking Strength	2 268 kg	5,000 lb	
<b>NOTE:</b> Wireline cable length to be specified at time of order.			
<b>ADDITIONAL INFORMATION</b>			
<b>Fuel Tank Capacity</b>	176 L	46 Gal	

# LF™ 90C Core Drill

## Technical Data Sheet



May 2009

Page 4 of 6

### DIMENSIONS AND WEIGHTS\*

#### WEIGHT

**Wet Weight** = 5 656 kg (12,469 lb)

#### Consisting of:

- Power Unit Group Cummins QSB 6.7 L, Tier 3, 6 cylinder
- Hydraulic Module
- Draw Works Grp. c/w 16,000 lb Main Line Hoist and Wireline Hoist c/w cable
- Hydraulic Mast Raising (Independent)
- Lower Mast Assembly
- 3-Piece Lattice Mast Assembly
- Rotation Unit Grp. c/w PQ Nitro-Chuck®/Head Guard
- Base Frame
- Fuel Tank 190 L/50 US gal)
- Battery - 12V
- Operator Platform
- Hydraulic Foot Clamp - HWT Capacity

#### OPTIONS

- Rod Racking Platform
- Hydraulic Leveling Jacks
- Towing Group - Dual Torque Flex Axles (oscillating)
- Hot Weather Hydraulic Cooling Group
- CE Certification
- Decals available in multiple languages
- Fluid circulation pumps (diesel supply and pressure)
- Mud mixer

**WARNING:** Do not operate this drill with rods racked in wind velocities in excess of

**NOTE:** Not highway rated

#### DRILL TRANSPORT POSITION C/W OPTIONAL TOWING GROUP

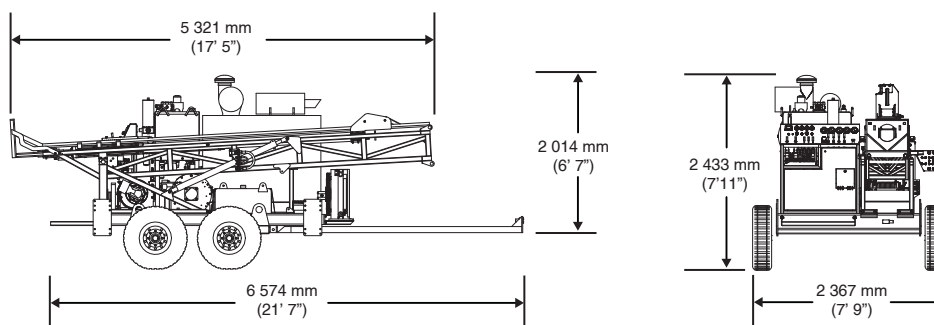

\* Dimensions and weights may vary depending on options and should be checked before crating or lifting.



### DIMENSIONS AND WEIGHTS\*

#### DRILL - MAST AT 90°

**NOTE:** Dimensions are with optional towing group and hydraulic leveling jacks extended to ground level. Leveling jack full stroke is 914 mm (36 in).

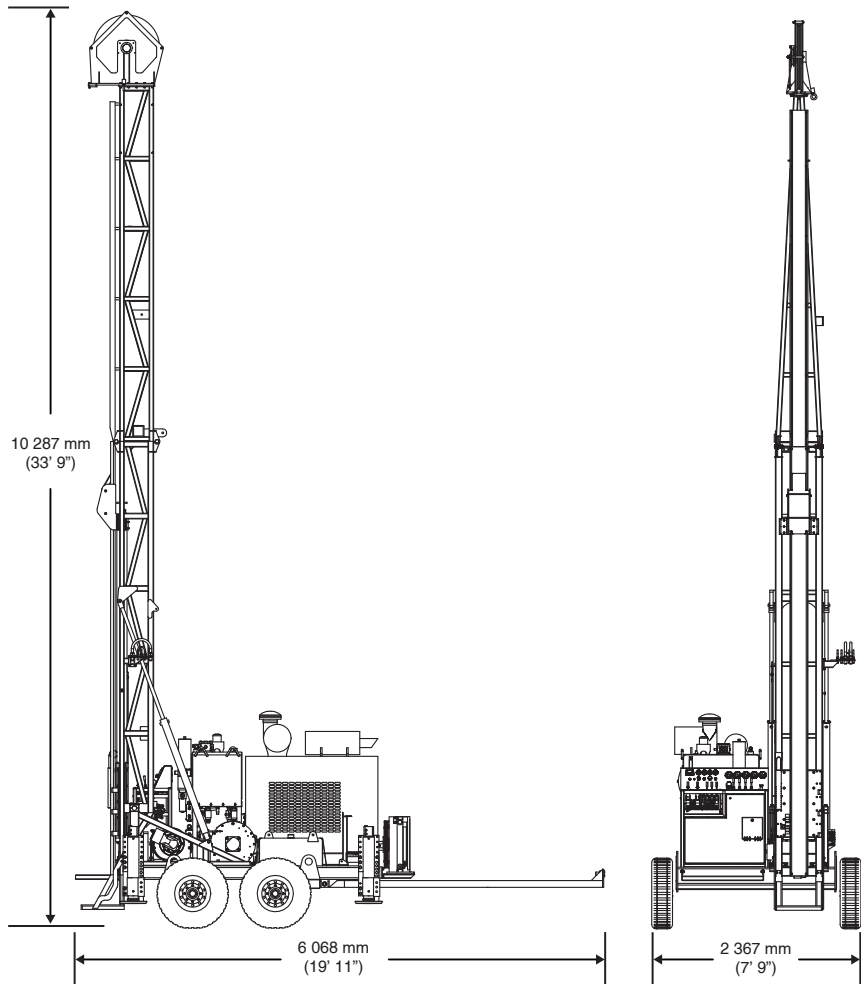

\* Dimensions and weights may vary depending on options and should be checked before crating or lifting.

# LF™ 90C Core Drill

## Technical Data Sheet



May 2009

Page 6 of 6

### DIMENSIONS AND WEIGHTS\*

#### (W11) FLUID CIRCULATION PUMP GROUP (OPTIONAL)

**Wet Weight = 254 kg (560 lb)**

The max. output of the standard 2-speed motor of the W11 is as follows:  
High vol./low pres. 35 gpm @ 300 psi 6.2 hp  
Low vol./high pres. 17 gpm @ 800 psi 7.9 hp

If a higher output pressure system is required an optional 2-speed motor can be supplied with the following max. output:  
High vol./low pres. 23 gpm @ 950 psi 12.7 hp  
Low vol./high pres. 11 gpm @ 1000 psi 6.4 hp

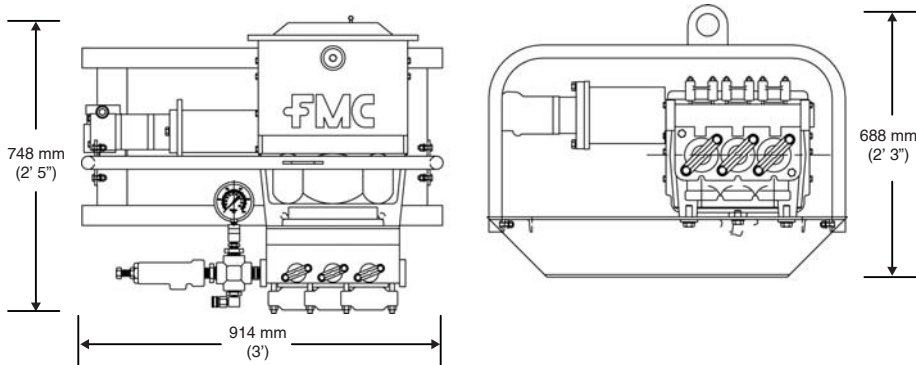

#### (L09) FLUID SUPPLY PUMP GROUP - DIESEL (OPTIONAL)

**Wet Weight = 145 kg (320 lb)**

The max. output of the standard 2-speed motor of the L09 is as follows:  
High vol./low pres. - 20 gpm @ 300 psi  
Low vol./high pres. - 10 gpm @ 800 psi

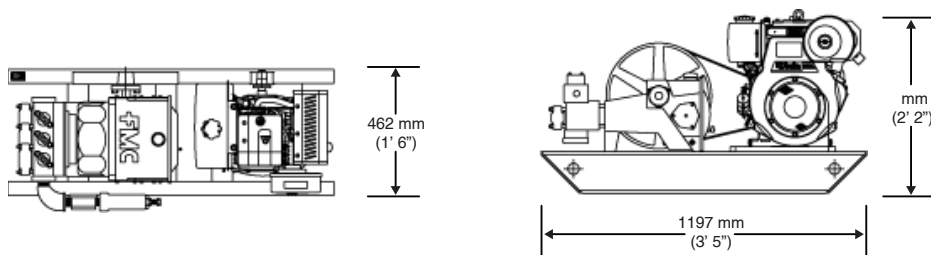

#### MUD MIXER ASSEMBLY (OPTIONAL)

**Wet Weight = 31 kg (68 lb)**

**NOTE:** Maximum speed of the mud mixer shaft at full flow is 2300 rpm.

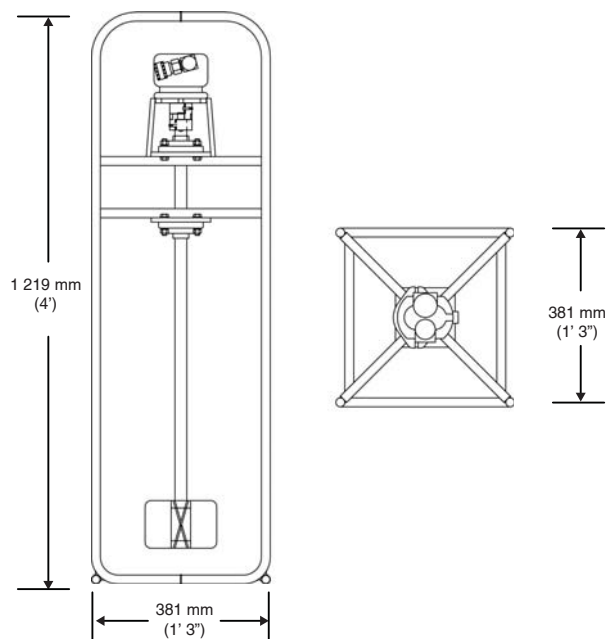

\* Dimensions and weights may vary depending on options and should be checked before crating or lifting.