

LF™ 230 Core Drill

Technical Data Sheet



May 2009

Page 1 of 7

PRODUCT OVERVIEW

It is considered to be one of the most productive deep hole drills in its class.

FEATURES:

- Dump mast — creates a stable working platform and lowers the working height dramatically.
- Patented Nitro-Chuck® — offers you performance and reliability (1 year warranty).
- Telescopic mast — compact transport size but still capable of 9 m (30 ft) rod pulls, easy onsite setup.
- Independent dual hydraulic mast raising cylinders.
- Mounting configuration — truck mounted for mobility.

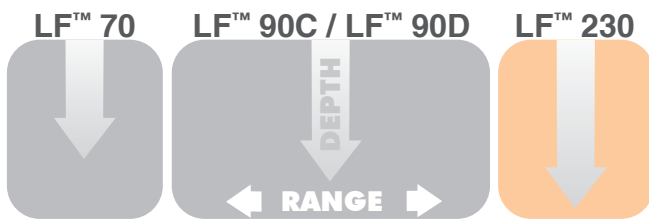
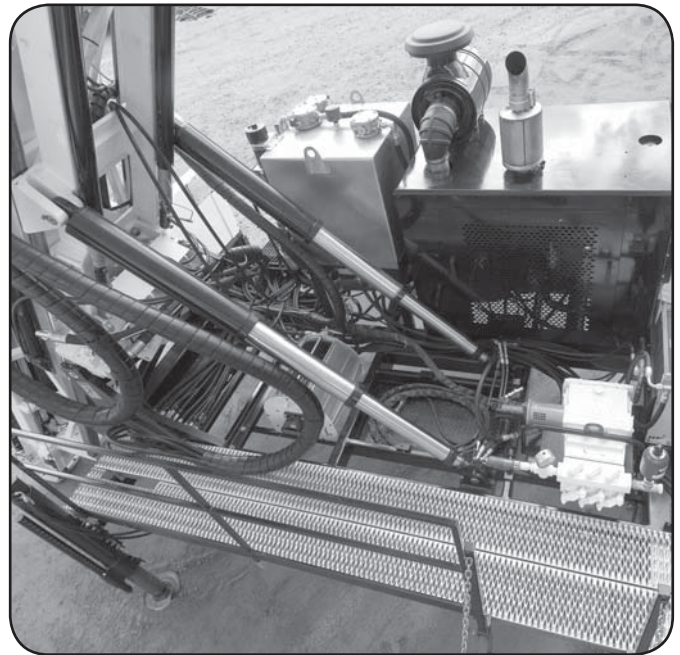

DRILLING DEPTH GUIDELINES

The figures in these tables have been calculated, based on field experiences, and may be reasonably expected. Ratings are based on a vertical, straight, clean down hole using a

18 258 kg (40,000 lb) hoist (single line pull). Actual drilling capacity will depend on in-hole tools, conditions, drilling techniques and equipment used.

| DRILL ROD / CORE BARREL | DRY HOLE | | FLUID FILLED | |
|-------------------------|---------------------|-------------------|---------------------|-------------------|
| | Hole Depth (meters) | Hole Depth (feet) | Hole Depth (meters) | Hole Depth (feet) |
| BRQ / BQ | 3 024 | 9,921 | 3 462 | 11,358 |
| BRQTK / BQTK | 3 806 | 12,488 | 4 360 | 14,306 |
| NRQ / NQ / NQ2 | 2 326 | 7,632 | 2 661 | 8,730 |
| NRQ V-WALL™ | 2 630 | 8,627 | 2 983 | 9,788 |
| HRQ / HQ | 1 578 | 5,176 | 1 806 | 5,925 |
| HRQ V-WALL™ | 1 987 | 6,518 | 2 246 | 7,368 |
| PHD / PQ | 1 043 | 3,421 | 1 190 | 3,904 |
| PHD V-WALL™ | 1 421 | 4,663 | 1 592 | 5,223 |

* BQ capacity shown for comparison purposes only. It is not recommended drilling practice to drill over 2 000 m BQ depth. Always verify manufacturers rod depth ratings prior to use.

LF™ 230 Core Drill

Technical Data Sheet



May 2009

Page 2 of 7

TECHNICAL SPECIFICATIONS

| | METRIC SYSTEM | U.S. CUSTOMARY SYSTEM | |
|--|--|-----------------------|---------------|
| PRIME MOVER | | | |
| Standard Unit | Cummins QSC 8.3 L, liquid cooled, turbo charged, charge air cooled engine. | | |
| Displacement | 8.3 L | 506 in ³ | |
| Power (maximum) at 2,200 RPM | 205 kW | 275 hp | |
| Emissions Certification | Stage III | Tier 3 | |
| TORQUE AND RPM RATINGS | | | |
| (Hydraulic motor at maximum/minimum displacement, prime mover at 2,200 RPM) | | | |
| | Speed (no load) | Torque (stall) | |
| | RPM | Nm | lbft |
| 1st Gear | 144 - 199 | 5 322 - 3 826 | 3,925 - 2,822 |
| 2nd Gear | 288 - 400 | 2 648 - 1 898 | 1,953 - 1,400 |
| 3rd Gear | 514 - 714 | 1 486 - 1 068 | 1,096 - 788 |
| 4th Gear | 900 - 1,250 | 849 - 610 | 626 - 450 |
| NOTE: Head output speed and torque are infinitely variable in each gear range as indicated. | | | |
| Actual rotation speed is affected by engine RPM and hydraulic motor displacement setting. | | | |
| HYDRAULIC SYSTEM | | | |
| Primary Pump | Axial piston, variable displacement, load sensing, pressure compensated with low pressure standby. | | |
| Max Flow | 318 L/m | 84 gpm | |
| Maximum Pressure (factory setting) | 31 MPa | 4,500 psi | |
| Secondary Pump | Axial piston, variable displacement, load sensing, pressure compensated with low pressure standby. | | |
| Max Flow | 72 L/m | 19 gpm | |
| Maximum Pressure (factory setting) | 21 MPa | 3,000 psi | |
| Auxiliary Pump | Axial piston, variable displacement, pressure compensated. | | |
| Max Flow | 42 L/m | 11 gpm | |
| Maximum Pressure (factory setting) | 14 MPa | 2,000 psi | |
| Hydraulic Tank Capacity | 435 L | 115 gal | |
| DRILL HEAD | | | |
| Rotation Motor | Rexroth hydraulic motor - variable/reversible | | |
| Mechanical Transmission | Funk 4 speed | | |
| Ratios | 1st | 6.27:1 | |
| | 2nd | 3.12:1 | |
| | 3rd | 1.75:1 | |
| | 4th | 1.00:1 | |
| Final Drive | Straight cut gears | | |
| Ratio | 2:1 | | |
| Head Opener | Pivoting style — hydraulically actuated | | |
| Hydraulic PQ Chuck | Patented Nitro-Chuck® Hydraulically opened, nitrogen gas spring closed. Axial holding capacity of 222 400 N (50,000 lbf) | | |
| Drill Head Lubrication | Force fed bearings, oil bath for gears, external sump | | |
| Drill Head Lubricating Oil Filtration | 25 micron suction oil filter | | |

LF™ 230 Core Drill

Technical Data Sheet



May 2009

Page 3 of 7

TECHNICAL SPECIFICATIONS

| | METRIC SYSTEM | U.S. CUSTOMARY SYSTEM |
|--|---|---------------------------|
| DRILL MAST AND FEED SYSTEM | | |
| Feed Stroke | 3.35 m | 11 ft |
| Feed Pull | 223 300 N | 50,200 lbf |
| Feed Thrust | 117 877 N | 26,500 lbf |
| Rod Pull | 6 or 9 m | 20 or 30 ft |
| Drilling Angle | 45° off horizontal to 90° vertical down | |
| Mast Dump (Crowd) | 2.74 m | 9 ft |
| Mast Telescope | 2.87 m | 9.42 ft |
| DRAW WORKS | | |
| Main Line Winch (40,000 lb) | Two speed motor | |
| Hook Load (single part line) | | |
| Bare Drum | 18 144 kg | 40,000 lb |
| Hoisting Speed (single part line) | | |
| Bare Drum | 72 m/min and 40 m/min | 236 ft/min and 131 ft/min |
| Main Line Winch Cable Dia. | 22 mm | 7/8 inch |
| Minimum Breaking Strength | 51 891 kg | 114,400 lb |
| NOTE: Do not use multiple part lines with the main line hoist, use single part line ONLY. | | |
| Foot Clamp Capacity HWT | | |
| Wireline Hoist | | |
| Level Wind | Chain driven - dual ratio | |
| Line Pull | | |
| Bare Drum | 907 kg | 2,000 lb |
| Full Drum | 510 kg | 1,125 lb |
| Line Speed | | |
| Bare Drum | 160 m/min | 525 ft/min |
| Full Drum | 284 m/min | 932 ft/min |
| Drum Capacity (6.4 mm/1/4" swaged) | 3 300 m | 10,827 ft |
| NOTE: Wireline cable length to be specified at time of order. | | |
| ADDITIONAL INFORMATION | | |
| Fuel Tank Capacity | | |
| (Short Frame) Standard | 238 L | 63 Gal |
| (Long Frame) Optional | 485 L | 128 Gal |

LF™ 230 Core Drill

Technical Data Sheet



May 2009

Page 4 of 7

DIMENSIONS AND WEIGHTS*

| WEIGHT | |
|---|---|
| Wet Weight ** = 13 607 kg (30,000 lb) | Consisting of: Power Unit Group Cummins QSC 8.3 L, Tier 3, 6 cylinder Hydraulic Module Draw Works Grp. c/w 40,000 lb Main Line Hoist with Cable, Wireline Hoist less Cable Hydraulic Mast Raising Hydraulic Mast Dump Telescopic Mast Assembly Rotation Unit Grp. c/w PQ NitroChuck® Base Frame Fuel Tank (485 L/128 US gal) Battery Hydraulic Leveling Jacks/Outriggers (Optional) Foot Clamp Mast Access Ladders Hydraulic Water Pump |
| OPTIONS | |
| Truck Mounted - International 5600 Catwalk, Railing and Access Stairs Rod Rack Platform (vertical holes ONLY) *** Hydraulic Cooler (hot climate) Mast Rest (truck mount version) Decals available in any language Fluid circulation pumps (diesel supply and pressure) Mud mixer | ** For high mobility, the mast mounted platform is kept lightweight. An optional rod rack is available for vertical holes only, otherwise rods are stacked on the ground. *** Limited to 22,000 lb of gross weight stacked at 5° off vertical mast. i.e. 140 x 30 ft stands NQ WARNING: Do not operate this drill with rods racked in wind velocities in excess of 85 km/h. This unit must not be operated without a truck or drilling skid base installed for stability. |

* Dimensions and weights may vary depending on options and should be checked before crating or lifting.

LF™ 230 Core Drill

Technical Data Sheet



May 2009

Page 5 of 7

DIMENSIONS AND WEIGHTS*

DRILL TRANSPORT POSITION - BASIC DRILL

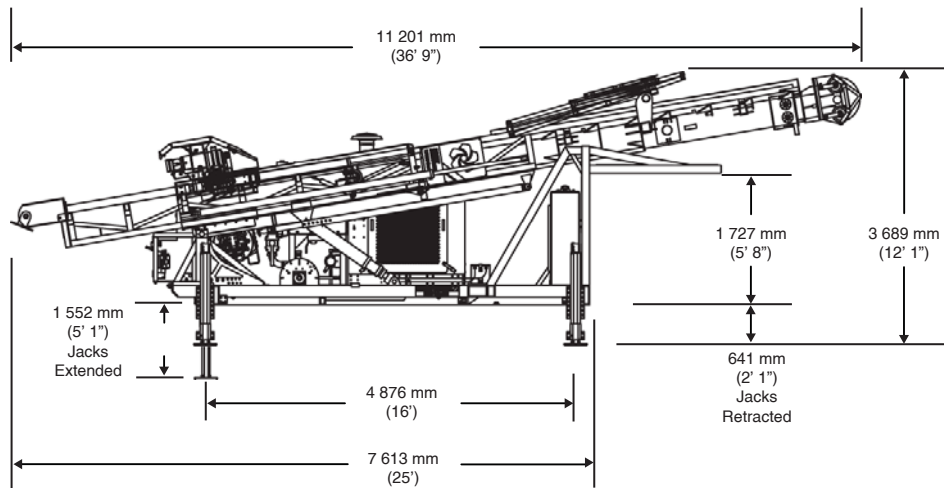

DRILL TRANSPORT POSITION CW OPTIONAL TRUCK

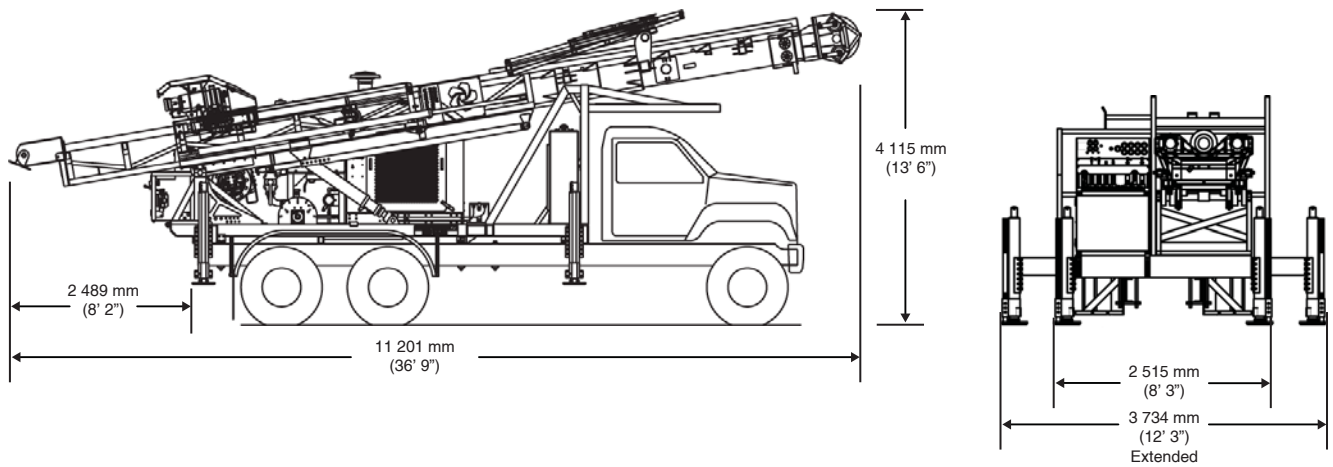

* Dimensions and weights may vary depending on options and should be checked before crating or lifting.

LF™ 230 Core Drill

Technical Data Sheet



May 2009

Page 6 of 7

DIMENSIONS AND WEIGHTS*

DRILL - MAST AT 90° C/W OPTIONAL TRUCK

Side view of drill with mast in 9 m (30 ft) pull

NOTE: Dimensions are with hydraulic leveling jacks extended to ground level. Leveling jack full stroke is 914 mm (3')

(shown with optional truck)

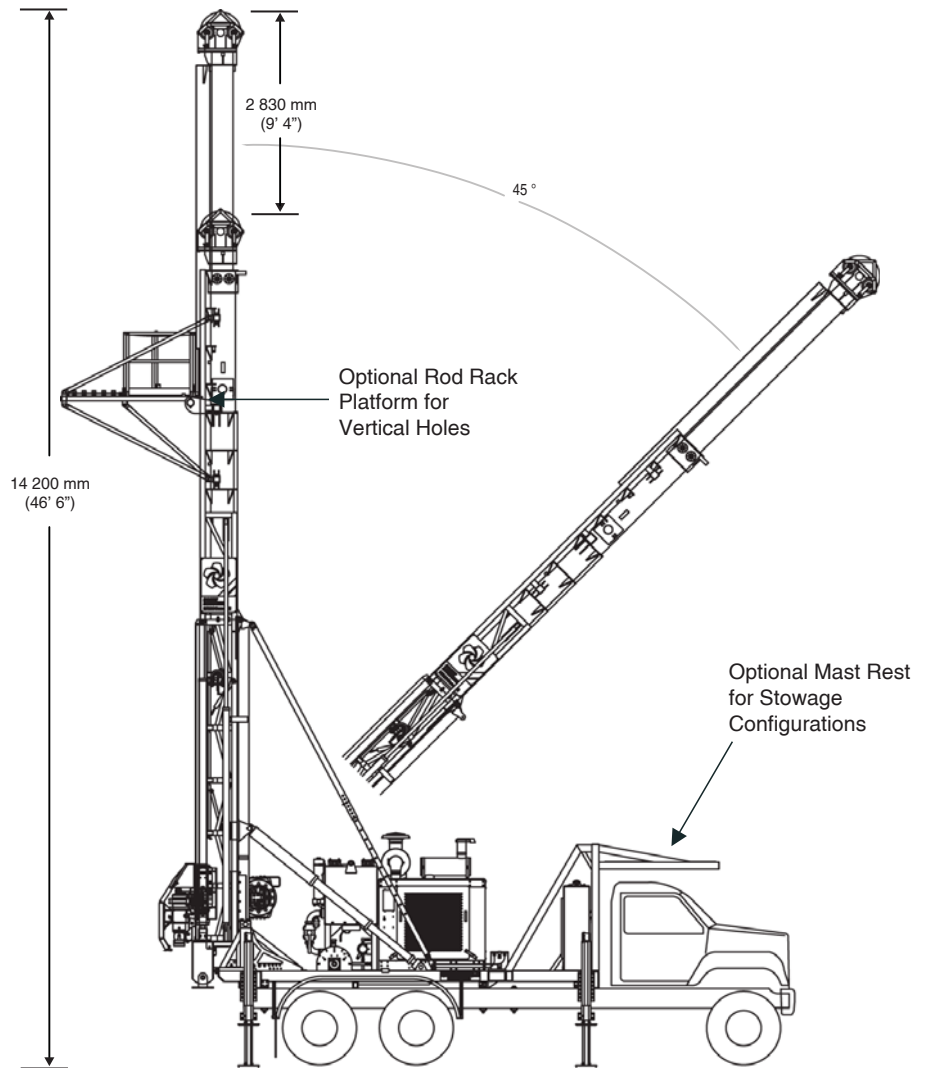

* Dimensions and weights may vary depending on options and should be checked before crating or lifting.

LF™ 230 Core Drill

Technical Data Sheet



May 2009

Page 7 of 7

DIMENSIONS AND WEIGHTS*

(W11) FLUID CIRCULATION PUMP GROUP (OPTIONAL)

Wet Weight = 254 kg (560 lb)

The max. output of the standard 2-speed motor of the W11 is as follows:
High vol./low pres. 35 gpm @ 300 psi 6.2 hp
Low vol./high pres. 17 gpm @ 800 psi 7.9 hp

If a higher output pressure system is required an optional 2-speed motor can be supplied with the following max. output:
High vol./low pres. 23 gpm @ 950 psi 12.7 hp
Low vol./high pres. 11 gpm @ 1000 psi 6.4 hp

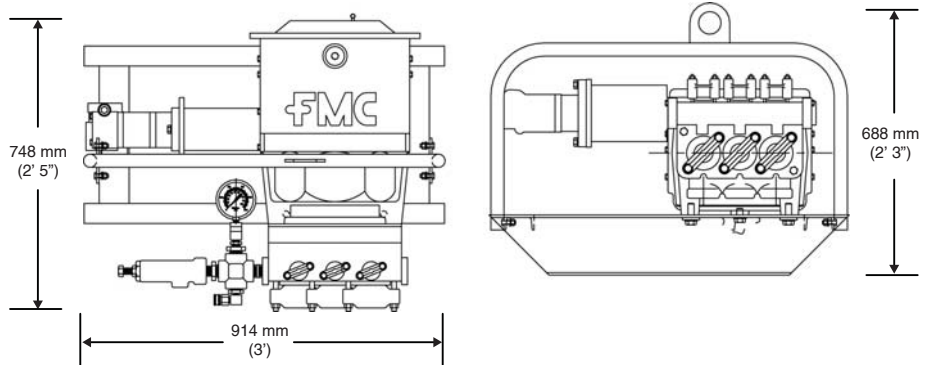

(L09) FLUID SUPPLY PUMP GROUP - DIESEL (OPTIONAL)

Wet Weight = 145 kg (320 lb)

The max. output of the standard 2-speed motor of the L09 is as follows:
High vol./low pres. - 20 gpm @ 300 psi
Low vol./high pres. - 10 gpm @ 800 psi

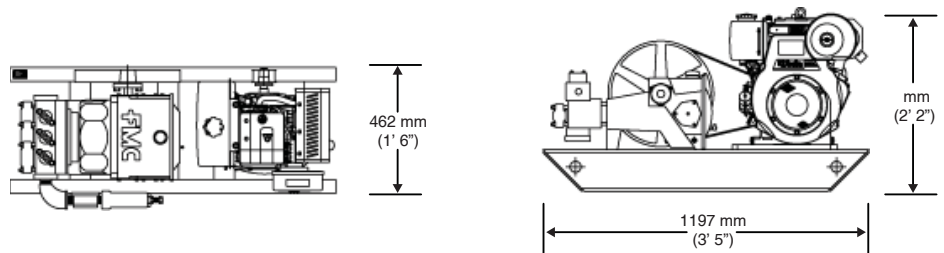

MUD MIXER ASSEMBLY (OPTIONAL)

Wet Weight = 31 kg (68 lb)

NOTE: Maximum speed of the mud mixer shaft at full flow is 2300 rpm.

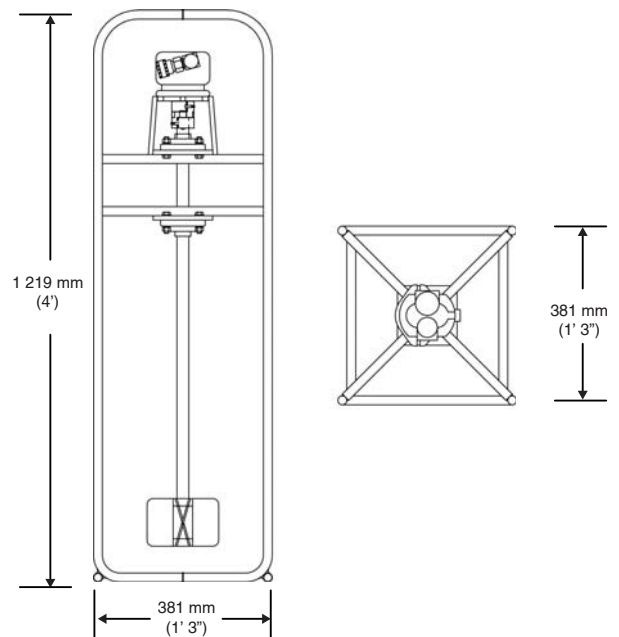

* Dimensions and weights may vary depending on options and should be checked before crating or lifting.