



# 500/650 HCI 1205

## 500 or 650 Ton 1205 HP Hydraulic Top Drive



### A versatile top drive for high performance applications

The HCI top drive system is the most versatile top drive in the TESCO product line.

Compact enough to fit into most double and triple masts for land based applications or offshore derricks, the HCI provides the performance and pipe handling features required for medium and deep drilling applications.

TESCO powers the HCI using industry proven prime movers and its own series of hydraulic pump drives and filtration equipment.

The HCI top drive is available with an optional integrated swivel or can use the customer's swivel. Casing load ratings of 500 or 650 tons are available.

Performance (torque and speed) can be customized using optional gear ratios and power unit selection.

### OPERATIONAL ADVANTAGES:

- The complete system including the top drive, torque system and power unit can be installed in less than one day. In most cases, no rig modifications are necessary.
- The HCI offers an expanded suite of pipe-handling functions including elevator link-tilt, and extend/retract feature for making mousehole connections (maximum extension 60 in.), 360° pipe-handler rotation, and grabber. The HCI grabber acts as a back-up tong for making or breaking connections and will accommodate tool joints from 3 in. to 8-3/4 in. OD.
- TESCO's unique quill design allows rapid field removal for inspection or replacement without draining the gear case.
- The HCI is equipped with an independent diesel engine or traction motor.
- A double ball mud saver/safety valve is incorporated into the system design.

# 500/650 HCI 1205

- The speed/torque ranges are selectable from the driller's console.
- The HCI track/torque bushing configuration is simple to install and requires minimal maintenance.
- The entire HCI can be transported in three standard 20 ft. sea containers.

## SPECIFICATIONS:

### HCI 1205 (with optional integrated swivel)

|   |                |               |
|---|----------------|---------------|
| Rated Capacity  | 500 /650 ton   | 454/590 tonne |
| Rated Power   | 1205 hp        | 900 kW        |
| Weight (with integrated swivel)                                       | 19,300 lbs.    | 8 770 kg      |
| Weight (without swivel)   | 12,300 lbs.    | 5 590 kg      |
| Operating Length (incl.9' links & elevators & with integrated swivel) | 240 in.        | 6 096 mm      |
| Operating Length (including 9' links & elevators & without swivel)    | 172 in.        | 4 360 mm      |
| Width   | 47.25 in.      | 1 200 mm      |
| Max. Drill Torque (2.76:1 gear ratio)                                 | 52,800 ft.-lb. | 7 158 daN-m   |
| Make-up Torque (2.76:1 gear ratio)                                    | 52,800 ft.-lb. | 7 158 daN-m   |
| Breakout Torque (2.76:1 gear ratio)                                   | 59,400 ft.-lb. | 8 053 daN-m   |
| Max Speed (2.76:1 gear ratio)   | 210 rpm        | 210 rpm       |
| Quill ID  | 2.5 in.        | 63.5 mm       |
| <b>Power Unit (DDI6V 2000)</b>  |                |               |
| Weight (approximate)  | 36,000 lb.     | 16 400 kg     |
| Length (c/w hose reel)  | 35 ft.         | 10 670 mm     |
| Width   | 6.25 ft.       | 1 910 mm      |

#### Top Drive Notes:

Weight includes top drive, pipe handler and torque bushing. The HCI can also be equipped with optional 500 or 650 ton integrated swivel. The top drive can be fitted with an optional 2.33:1 gear ratio.

Smaller critical dimensions are possible in some configurations – detailed rig measurement required.

#### Power Unit Notes:

Other power unit options are available. Power unit workshop containers and stacking kits are also available.

## PERFORMANCE CURVE:

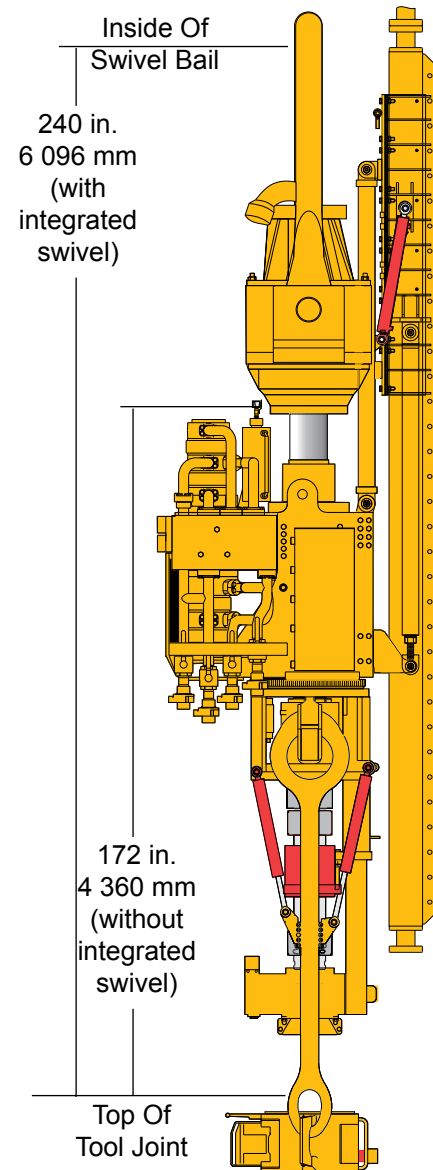
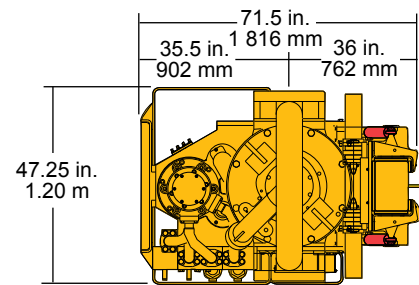
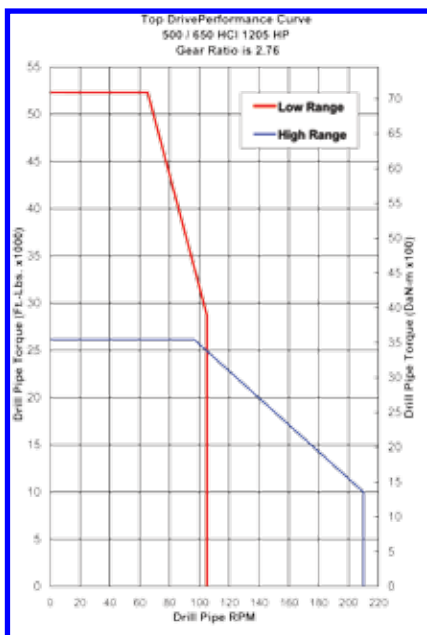

Printed in Canada / August 2006 / P04  
Due to ongoing product development, all specifications are subject to change without notice.

**Better Ways to The Bottom™**  
Email: [topdrive@tescocorp.com](mailto:topdrive@tescocorp.com) Web: [www.tescocorp.com](http://www.tescocorp.com)



**Corporate Headquarters**  
6204 - 6A Street S.E.  
Calgary, Alberta, Canada T2H 2B7  
Tel: 403 692-5700 • Fax: 403 692-5710

**World Wide Operations**  
11330 Brittmoore Park Drive  
Houston, Texas, USA 77041  
Tel: 713 849-5900 • Fax: 713 849-0075