



## 350 EXI 600 Top Drive

BULLETIN 20150e



### The 350 ton, Model EXI 600HP Extreme Top Drive is a Full-Featured Electric Top Drive for Small-Mast Applications

**T**he TESCO Model 350 EXI 600 Extreme electric top drive system is a compact, full featured, top drive with horizontal drilling in mind for smaller narrow mast drilling rigs.

- Standardized parts that can be serviced easily and are readily available.
- Improved gear system and pipe handling arrangement.
- Easy access for maintenance and service.
- Supports multiple Variable Frequency Drives for easy integration.
- Fully portable design with optional portable Variable Frequency Drive.
- 24/7/365 Worldwide Technical Support and Service.
- TESCO has the best reliability and service record in the industry. Our Portable Top Drives are designed to be compatible with innovative drilling technologies – such as the Casing Drive System™ and CASING DRILLING® services.

**Value Added Operational Benefits**

- The complete system including the top drive, torque system, and optional VFD building can be installed in less than one day. Minimal rig modifications are necessary.
- The 350 EXI 600 is available with an optional genset. The drive can be independently packaged as a cabinet or building. The top drive can also be easily integrated with most existing VF drive configurations.
- The 350 EXI 600 offers all critical pipe-handling functions including elevator link-tilt, 137.2mm (54in.) extend/retract (for making mousehole connections), and 360° pipe handler rotation. The grabber will accommodate tool joints from 76.2mm (3in.) to 222.25mm (8 3/4in.) OD.
- The 350 EXI 600 top drive's unique design integrates the swivel, gearbox and PH. Spool resulting in a very compact unit but maintains the serviceability expected from a TESCO top drive.
- The 350 EXI 600 system incorporates programmable logic control. PLC ensures flawless communication between the driller's panel and the drive system. The PLC system optimizes efficiency and provides important safety interlocks.
- The 350 EXI 600 package includes a customizable torque arrest system. The track/torque bushing configuration is simple to install and requires minimal maintenance. A mud saver/safety valve is incorporated into the system design.
- The entire 350 EXI 600 top drive can be transported in three standard 6.09m (20ft.) sea containers and the top drive may be transportable in the mast for quick rig up.

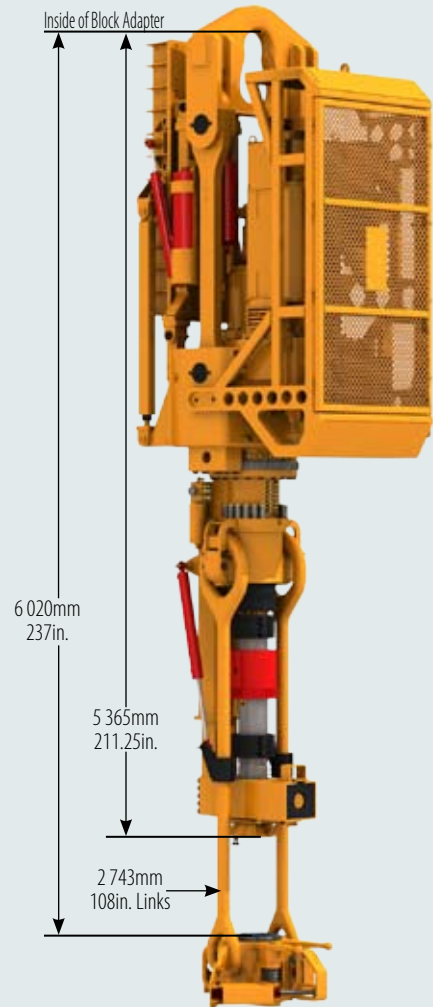
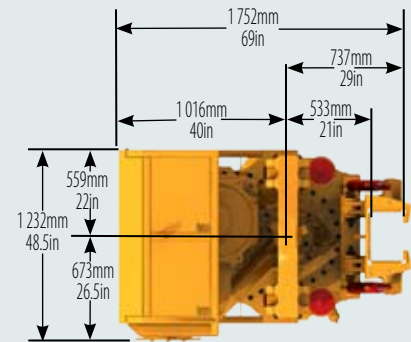
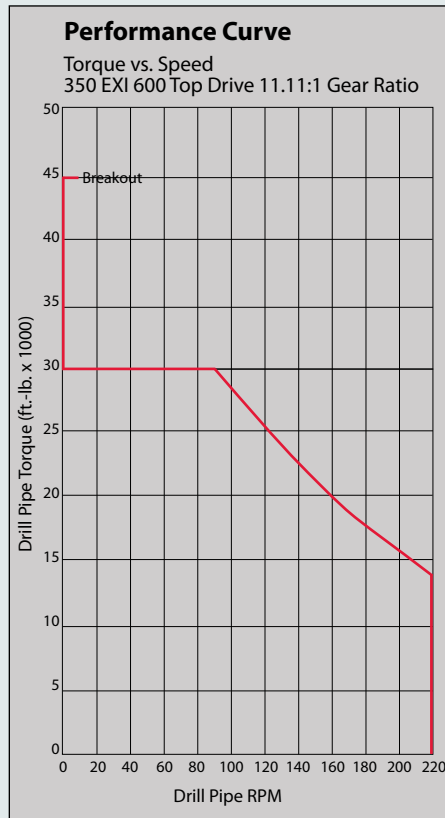

**Specifications**

350TON EXI 600HP (with a 350 ton integrated swivel)	Imperial	Metric
Rated Capacity	350ton	317tonne
Rated Power	600HP	447kW
Hook Weight	25,000lbs.	11 340kg
Operating Length (including 9 ft. links)	237in.	6 020mm
Width	48.5in.	1 232mm
Max. Continuous Drill Torque	30,000ft.-lb.	4 067daN-m
Make-up / Breakout Torque	45,000ft.-lb.	6 101daN-m
Max Speed	220RPM	220RPM
Quill ID	3.0in.	76.2mm
Quill Connection	NC61 SRG	

TESCO®, CASING DRILLING®, Casing Drive System™, CDS™ and Better Ways to The Bottom™ are trademarks of Tesco Corporation  
©Tesco Corporation / June 2007 / POD / Due to ongoing product development, all specifications are subject to change without notice.

**Asia Pacific**  
Jakarta, Indonesia  
Email: APBU\_sales@tescocorp.com

**China**  
Chaoyang District, Beijing  
Email: CHINA\_sales@tescocorp.com

**Europe/Russia**  
Aberdeen, UK  
Email: EURO\_sales@tescocorp.com

**Latin America**  
Buenos Aires, Argentina  
Email: LABU\_sales@tescocorp.com

**Middle East & Africa**  
Dubai, UAE  
Email: MABU\_sales@tescocorp.com

**United States / Canada**  
Houston, Texas / Calgary, Alberta  
Email: NABU\_sales@tescocorp.com

